

Arpool Micro

TECHNOLOGY



Split & Seal

Uses protective polymers to shield Filix products from water and moisture, boosting durability and resilience.



Flow Sense

A built-in protector against power-related issues, ensuring lasting performance and safety





Arpool Micro

Specification Sheet

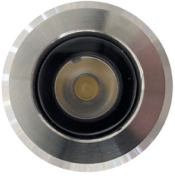

IP68

ISO 9227:2017 Salt Spray tested for 500 hours

UL STD 676 swimming pool rated (pending)

LUMINAIRE FEATURES

Design and Application

- Small-scale pools and water features
- Low output recessed spotlight

Mechanical details

- IK10 crystal-clear tempered glass, 8mm (0.31") thick
- IP68, rated for permanent submersion
- Maximum installation depth up to 5m (16')
- AISI316L stainless steel body
- Suitable for chlorine and marine environments
- Supplied with 3m(10') oil and water resistant feed cable as standard
- Recessed press-fit installation
- Equipotential bonding point available with stainless steel housing

Electrical details

- LED Lifetime TM-21 @ 105°C L80(24K) = 145,000 hours
- Operating temperature: -20°C (-28°F) to +50°C (122°F)
- LED CRI: >85
- 3 step MacAdam
- Remote power supply
- Low voltage operation

Sustainability

- Recyclable material

Controls

- DMX, with compatible LED power supply
- DALI, with compatible LED power supply
- 0-10V, with compatible LED power supply
- Mains, with compatible LED power supply

Integrated systems

- Split & Seal
- Flow Sense

Links & Downloads

- [List of available drivers](#)
- [Voltage drop calculator](#)
- [Fixture installation manual](#)
- [Housing installation manual](#)
- [CAD files](#)
- [IES-LTD data](#)

Note

Underwater luminaire – must be constantly submersed.



Arpool Micro

ORDERING INFORMATION

MODEL**AU****APPLICATION****TM**

- TM - Ø35mm x H-47mm (Ø1,37" x H-1,9")

POWER**L**

- L - 1,5W; 2700/3000/4000K, 180 lm
- L - 1,5W; TW (2200K-4000K)

COLOR TEMP.**27**

- 27 - 2700K

30

- 30 - 3000K

40

- 40 - 4000K

T6

- T6 - Tuneable white 2200K-4000K

OPTICS**SP**

- SP - Spot (15°)

MF

- MF - Flood (40°)

WD

- WD - Wide (70°)

INPUT TYPE**CC**

- CC - max. 500mA constant current input

OPTIONS**03**

- 03* - Standard feed cable 3m (10')

06

- 06 - Luminaire supplied with 6m (20') feed cable

09

- 09 - Luminaire supplied with 9m (30') feed cable

15

- 15 - Luminaire supplied with 15m (50') feed cable

20

- 20 - Luminaire supplied with 20m (65') feed cable

INTERNAL LIGHT**CONTROL****2**

- 2 - Hex Lovre

4

- 4 - Half Moon

5

- 5 - Honeymoon



Arpool Micro

MANDATORY ACCESSORIES

Housings

HOUSING

AU

- AU - AISI316L installation housing

TAU

- TAU - Technopolymer installation housing

Power supplies

DRIVERS

[LINK](#)

- List of available drivers

OPTIONAL ACCESSORIES

205117

- 205117 - Socket wrench for cable gland



Arpool Micro

INSTALLATION DETAILS

Fixture

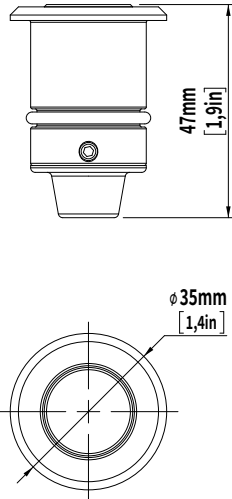

Housings

Stainless steel installation housing

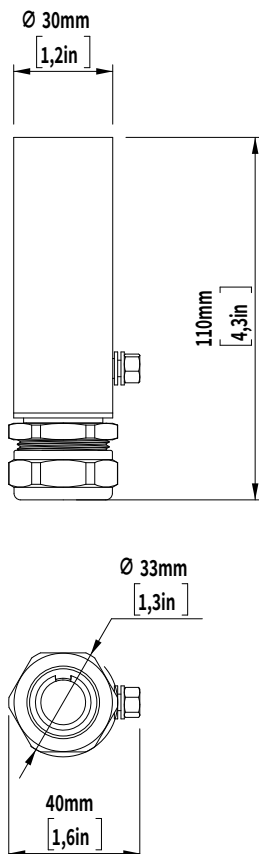

Technopolymer installation housing

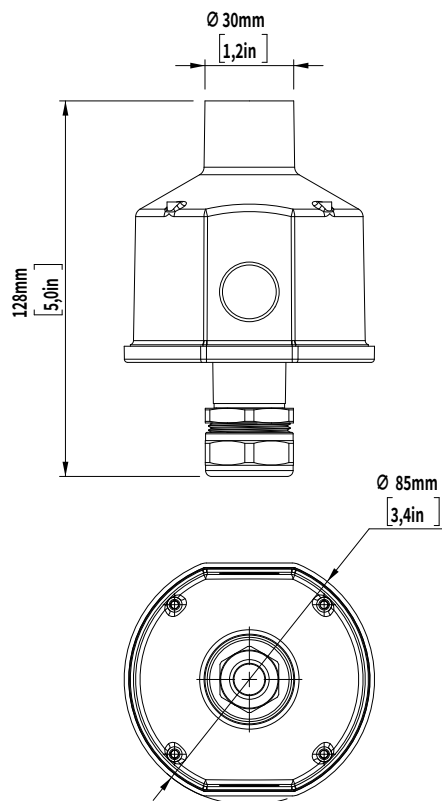

Note:
For details on specific depths, tiling thickness and other please refer to both Installation instructions for fixture and housing.



Arpool Micro

MANDATORY ACCESSORIES

AISI316 installation housing

Stainless steel niche used to seamlessly integrate luminaire utilizing precision press fit with no exposed hardware. The housing, chemically etched and passivated, is suitable for marine and pool environments. Standard features include a 1.5m oil and water-resistant cable conduit, streamlining the installation process. Due to its size, the housing's back end intentionally lacks a sealed cable gland. Contractors are advised to review installation instructions for proper guidance.

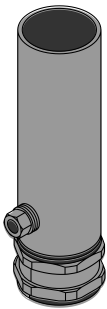

Technopolymer installation housing

The niche enables a smooth installation of the luminaire, featuring a precise press fit with no visible hardware. Constructed from durable technopolymer, it features a single cable entry and is suitable for both marine and pool environments. Standard features include a 1.5m oil- and water-resistant cable conduit, streamlining the installation process. The housing is IP68 rated with a sealing cable gland and is designed to accommodate 1.5m of cable to facilitate easier repairs.

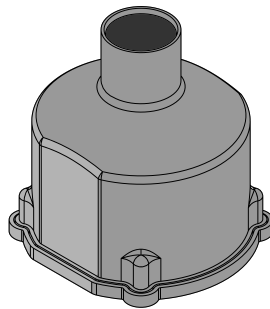

Power supply

A LED power supply, is an electrical device designed to control the power supplied to an LED or an array of LEDs. It plays a critical role in LED lighting systems as LEDs demand a specific type and level of electrical current or voltage for optimal operation. It's important to note whether a constant current or constant voltage LED power supply is required. The power supply should be installed in a dry and easily accessible area.

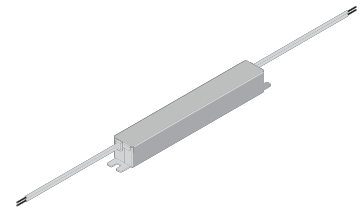



Arpool Micro

LIGHT CONTROL

Internal light control:

Hex louvre

Provides low glare control with 45% less lumen output than product without louvres. Best for use when there is no need for segment beam cut off such as in half moon.

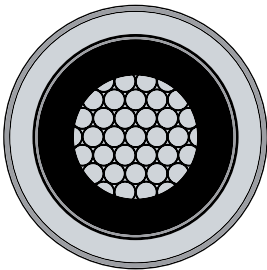

Halfmoon

Provides glare control by reducing lumen output and implementing a light beam cut-off, resulting in a 50% reduction in stray light and minimized light dispersion in undesirable directions.

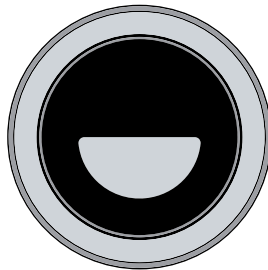

Honeymoon

Combines the benefits of Hex Louvre and Halfmoon, offering both reduced glare and controlled light dispersion for comprehensive glare management.

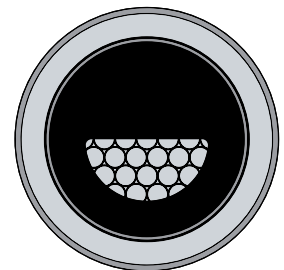



Arpool Micro

OPTICS

Spot
Angle: 15°
Delivered lumen: 180lm

Flood
Angle: 40°
Delivered lumen: 125lm

Wide
Angle: 70°
Delivered lumen: 80lm

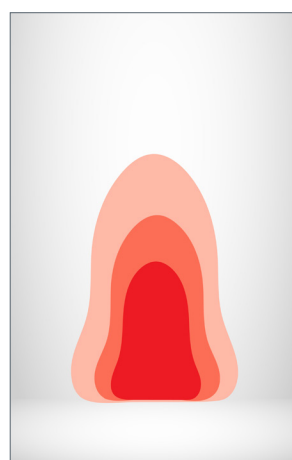
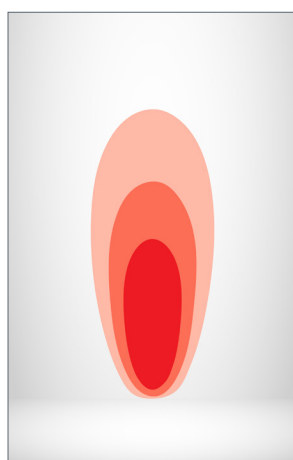
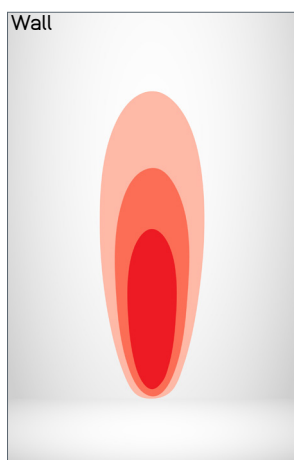
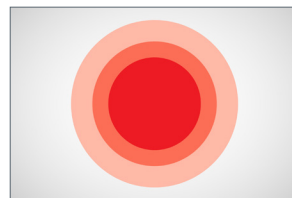
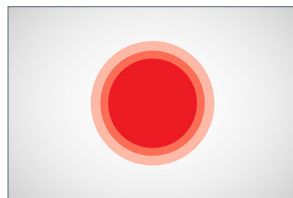
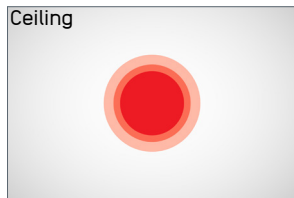

Spot + Hex
Angle: 15°
Delivered lumen: 130lm

Flood + Hex
Angle: 40°
Delivered lumen: 75lm

Wide + Hex
Angle: 70°
Delivered lumen: 50lm

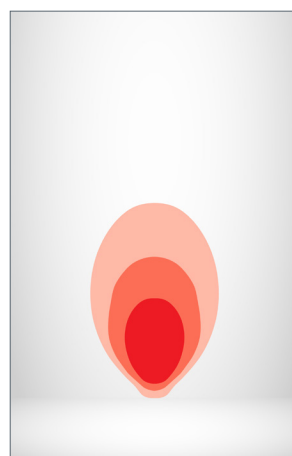
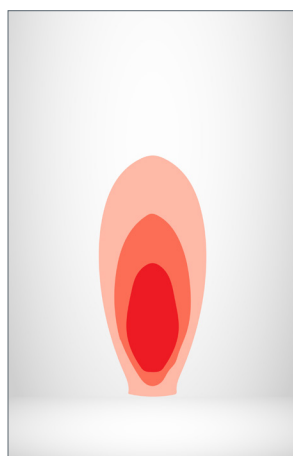
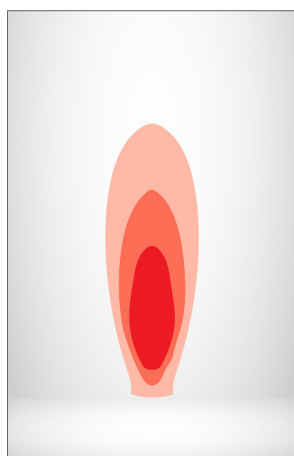
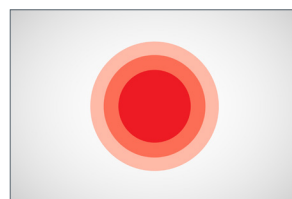
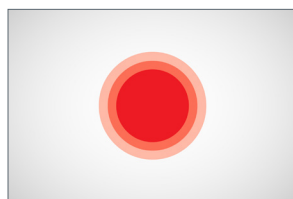
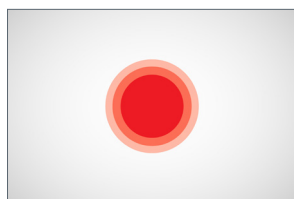

Notes

- Light output values based on 1,5W and 4000K product



Control

SYSTEM TOPOLOGY - CONSTANT CURRENT

System components

- The luminaire is supplied with a factory-installed feed cable in standard lengths for connection to the PSU circuit, and mounting hardware as specified in the installation instructions.
- A compatible constant current LED driver, series connection cabling between the driver and luminaires, junction boxes, connection infrastructure, and the control system (DALI, DMX, 0–10V or switching) must be provided by the installer or customer.
- Recommended components:
 - Surge protection on the AC side of the driver
 - Connectors and junction boxes suitable for the installation environment
 - Drivers with compatible dimming interfaces required by the project

System topology

- Constant current systems use a series connection topology where luminaires are connected sequentially within a single driver circuit.

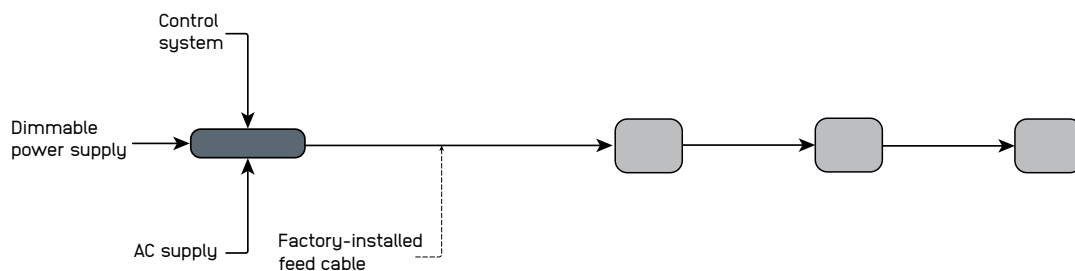

Addressing & dimming notes

- Individual device or channel addressing can be achieved by connecting each product to a separate output channel of the DALI or DMX compatible driver.
- The driver adjusts output current according to the control signal to regulate light output.
- Dimming options depend on the PSU and the selected control system.

Segment length and limitations

- The minimum controllable segment is one product
- Maximum number of luminaires depends on the driver output current and total forward voltage of the connected luminaires
- The total forward voltage must remain within the driver operating range

Fault tolerance

- Failure of the control system or communication bus does not interrupt luminaire operation if the driver continues to supply current.
- Failure of one luminaire may interrupt operation of the entire circuit due to the series connection topology.
- System reliability depends on correct driver selection and proper electrical installation.